

Electical Characteristics 電氣特性

P/N: VR162N11CUP-A1K~A1M L16R/φ 6.35/M8-6.5/TIN/GN

總阻值(R) Total resistance	1K ~1M
總阻值容許誤差 Total resistance tolerance	±20% (More than 1MΩ±30%)
阻值線性 Resistance taper	A
摺動雜音 Sliding noise	Less than 47mV
殘留阻值 Residual resistance	≤ 20 Ω (R > 10K) ≤ 10 Ω (R ≤ 10K)
定格電力 Rated power	K: Linear(B)taper:0.2W Other taper:0.1W T: Linear(B)taper:0.125W Other taper:0.06W
最高使用電壓 Max. operating voltage	Linear(B)taper:200V Other taper:150V
絕緣阻抗 Insulation resistance	More than 100 MΩ at DC 500V
耐電壓 Withstand voltage	1 minute at AC 500V

Mechanical Characteristics 機械特性

全回轉角度 Total rotational angle	300°±5°
全回扭轉力 Rotational torque	20~300 gf.cm
C.C 扭力 C.C torque	100~350 gf.cm
軸推拉強度 Shaft push-pull strength	7Kgf max
全回轉止強度 Rotatonal stopper strength	8Kgf max
迴轉壽命 Rotationallifc	15,000 cycles

General 一般事項

使用溫度範圍 Operating temperature	-10°C ~+70°C
手工焊接 Manual soldering	300°C max 3 sec

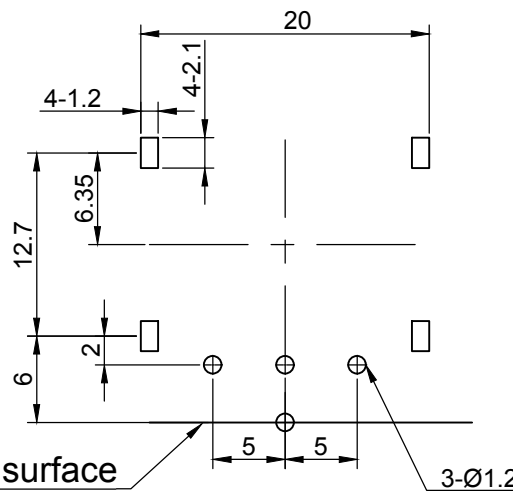
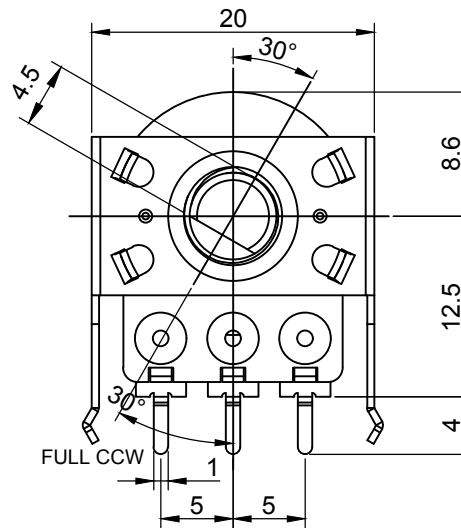
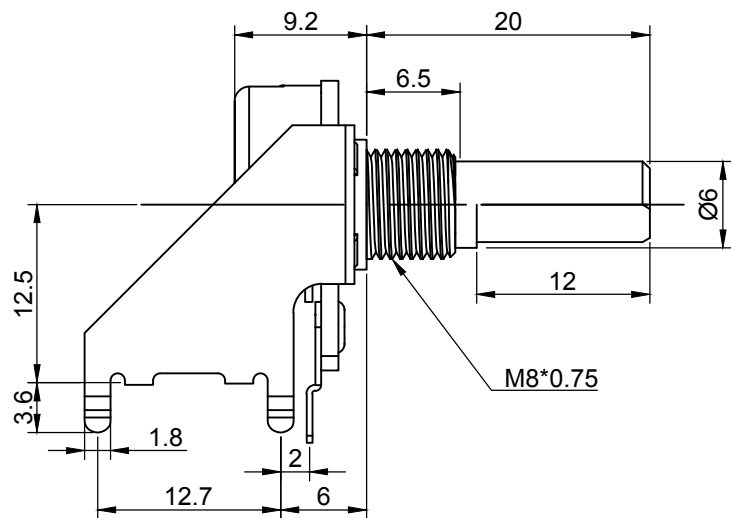

M8*0.75

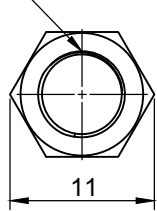

NUT

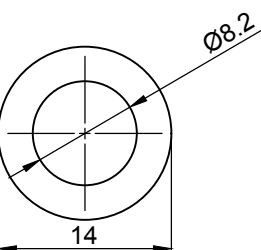
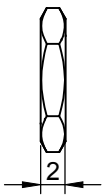

T=0.4
WASHER

CIRCUIT

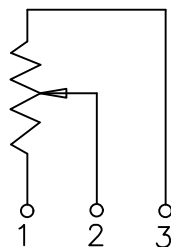

TOLERANCE	
UNEDR 10	± 0.3
10 ~ 100	± 0.5
OVER 100	± 0.8

MODEL : VR162N11CUP-A1K~1M-L16R/Ø6.35/M8-6.5/TIN/GN

APPROVAL BY



CHECK BY



MADE BY



UNT: MM

EDITION: 1.0

CUSTOMER CONFIRM(客戶認可簽章)

NO:

TAPERS 15A (JIS:A) SERIES

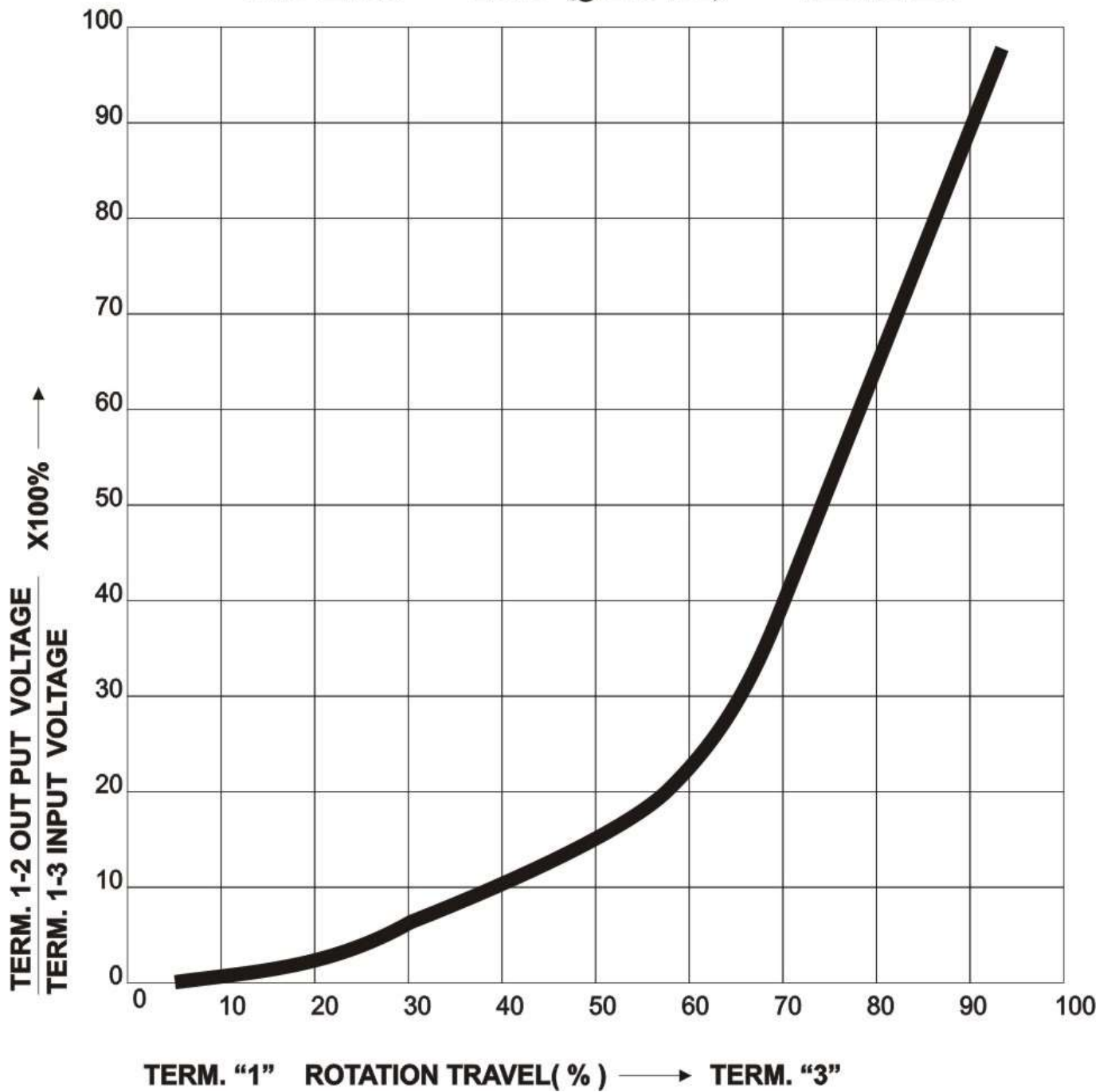

电阻变化特性之测量:是由轴(或滑动柄)于规定子间(端子1和2)与端子1和3间的电阻变化率计算得出。

Approved By	Checked By	Drawn By	Drawing No	Sample No
			DY-FM-I-809	110322-B4714